

TRON Spinning Disc LED Effect Mod Kit Installation Guide



Table of Contents

Product overview.....	2
What's included.....	2
Tools Required.....	3
Installation instructions.....	3
Troubleshooting.....	9



The Lundy Electronics **TRON Spinning Disc LED Effect Mod Kit** is a hardware and firmware design variant based on Ashram's Github open source project found at <https://github.com/Ashram56/Tron-Pinball-Disc-Mod>.

Product overview

The Lundy Electronics **TRON Spinning Disc LED Effect Mod Kit** is designed to replace the existing factory lamps beneath the spinning disc mechanism and instead use an LED ring to produce creative lighting effects when the spinning disc is idle or moving. These effects include an orange "dual scan" when idle, blue clockwise "comet" spin, red counterclockwise "comet" spin, and no activity when general illumination is off.

The device will detect when the general illumination lights are on/off and will turn the LED ring effects on/off accordingly for consistent integration with original factory effects that turn general illumination off to showcase certain mode effects. Firmware has been changed to use a different idle effect and accelerates both red and blue spinning LED ring effects for a more pronounced look.

A custom Lundy Electronics Controller PCB integrates an Arduino NANO to all the necessary inputs, outputs, power connections, and associated circuitry needed to control the LED ring. This mod requires no soldering.

What's included

- Controller PCB
- PCB power tap and six-pin wire tap motor direction sense combination wiring harness
- LED ring assembly with wiring harness and bracket
- General illumination alligator clip wiring harness
- Disc shim
- Lower ring mounting bracket
- Ring bracket mounting hardware
- Cable ties
- Adhesive tape
- Optional "Pro Power Harness" only required for TRON Pro model machines



Tools Required

- 11/32" wrench
- 5/16" wrench
- 1/4" nut driver
- Phillips screwdriver
- Razor blade
- Angled pliers
- Electrical tape

Installation instructions

Step 1: Power on the TRON machine. Open the coin door, and pull out the door safety switch to enable playfield power. Enter service mode and select DIAG > GAME > BANK and press SELECT to lower the three-bank target assembly. Lowering the three-bank target assembly now will make adjusting the spinner assembly height easier after installation of the **Spinning Disc LED Effect Mod Kit** is completed. Power unit off.

Step 2: With the machine powered off, balls removed, and playfield raised to a full upright position, mount the Lundy Electronics TRON Spinning Disc LED Effect Mod control PCB with the supplied double-sided sticky PCB mounts. See **Figure 1** for correct placement and orientation shown on an LE model. This area is just below the pops and just above the power resistor pack on the right side of the playfield.

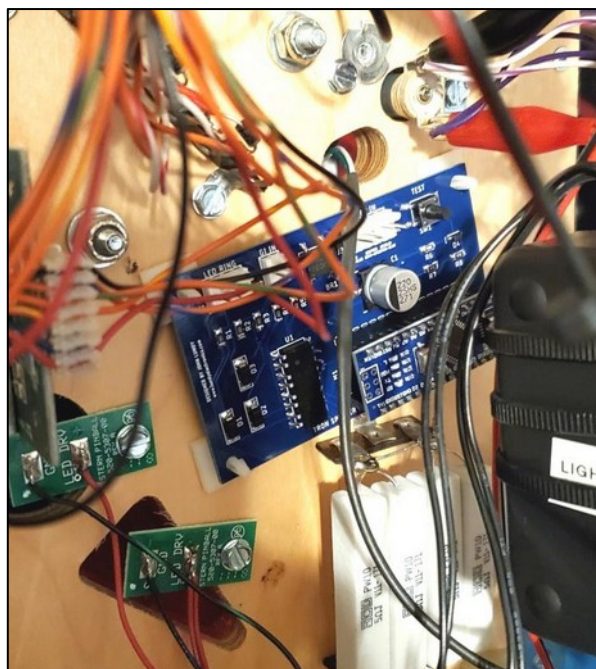

Figure 1

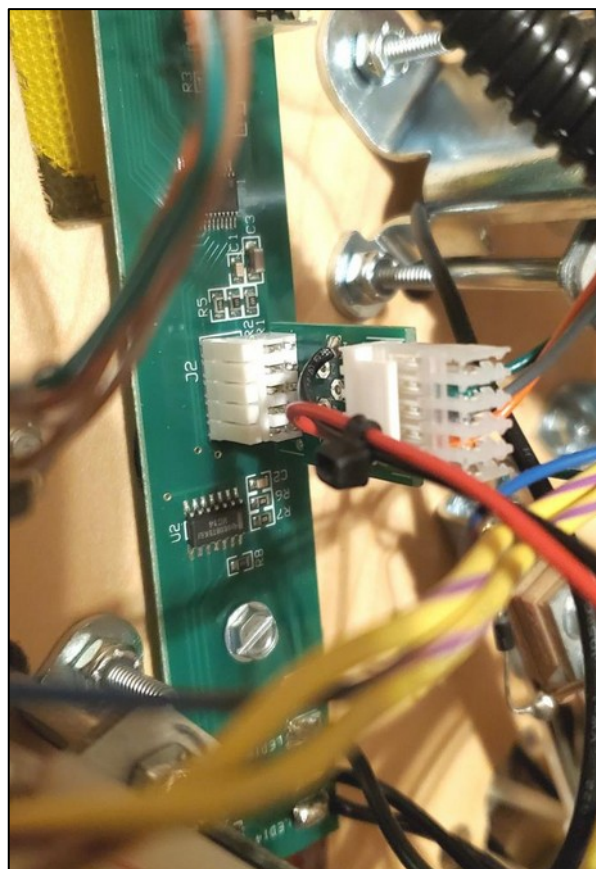

Figure 2

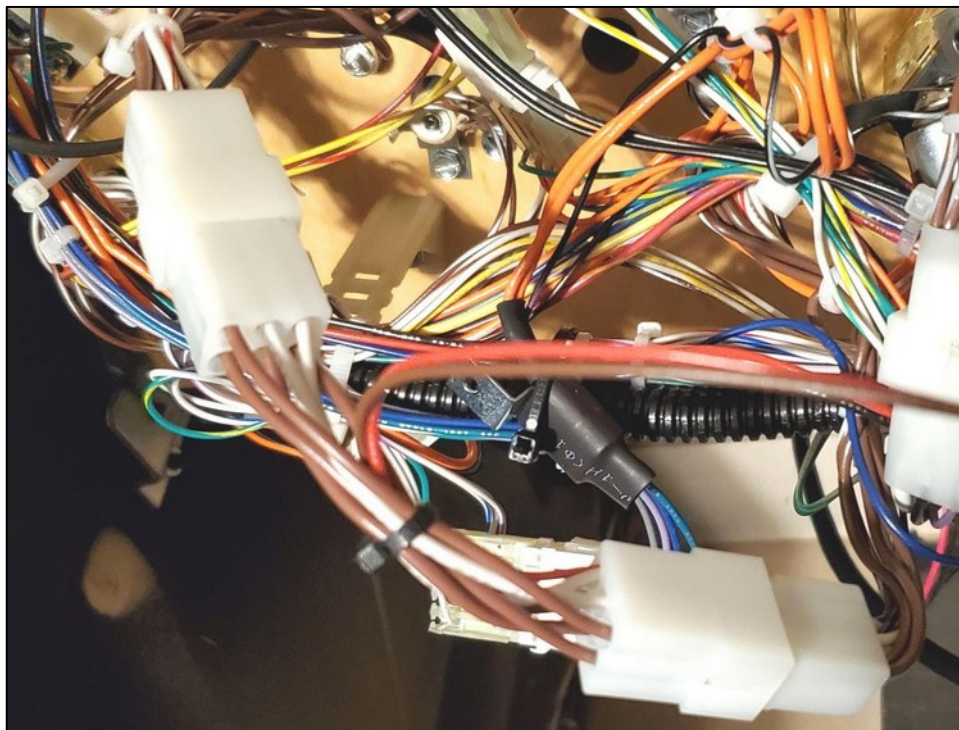

Figure 3

Step 3: Install the supplied LE model PCB power tap and six-pin wire tap motor direction sense combination wiring harness as shown in **Figures 2 and 3**. The six-pin wire tap is connected between the factory disc direction relay assembly connector located at the lower left under the playfield. The LE model location is shown in **Figure 2**. The LE model PCB power tap is attached at the 520-5315-02 LED lamp board (closest to the pop bumpers) and is sandwiched between the factory J2 connector and original wiring harness. Pro model owners need to use the optional “Pro Power Harness” and see note below. Attach the single five-pin keyed connector from the other end of the attached power tap and six-pin wire tap motor direction sense combination wiring harness to the J3 “POWER IN” connector of the Controller PCB.

*Note: PCB power tap is only for LE models. Pro models require disconnecting the two-pin PCB end connector and instead attaching a “Pro Power Harness” that supplies power from the three-pin connector near the inside cabinet service power outlet box located at the front bottom right of the cabinet. **This option is selected at checkout on the product page of the Lundy Electronics website for an additional fee.***

Step 4: Install the supplied yellow general illumination alligator clip wiring harness to J2 “GI IN” connector of the Controller PCB. Attach the clips to any available general illumination lamp socket tabs near by. The clip order on socket tabs does not matter. Verify solid connections without any shorts. See **Figure 4**.



Figure 4

Step 5: Remove the four lamp sockets under the spinning disc assembly. They will no longer be used. The bulbs can be removed, sockets wrapped in electrical tape, and cable tied out of the way or screwed back in place without bulbs last after this mod installation is completed.

Step 6: Remove the spinning disc assembly by disconnecting the single two-pin Molex connector from the spinning disc motor assembly. Remove the four 1/4" hex head screws allowing the entire spinning disc assembly to be lowered out of the playfield. On a safe work surface, the following procedure needs to be performed to the spinning disc assembly. *Note: Due to the type of factory thread locker and torque used, it hasn't been possible to remove the set screw on the top disk hub that mounts the plastic disc. Therefore, this procedure describes the alternate method of installing the mod without the need to loosen the set screw.*

1. Carefully remove the top center rubber disc adhesive pad to expose the disc mounting screws. See Item 3 of **Figure 5**. The adhesive on the rubber pad can be removed by rubbing it off with your thumb. Set the rubber pad aside for later use.
2. Remove the three disc mounting screws and associated 8-32 nylon lock nuts using a 11/32" wrench and Phillips head screwdriver. See Items 5 and 6 of **Figure 5**. Space is tight, and you will find it's helpful to find a spot with the most room to reach in and hold the nuts. Spin the disc as necessary to reach the remaining two nuts from the same location. *Note: Loosening the two side assembly height adjustment screws using a 5/16" wrench will allow you to pull the top portion higher out of the way to make more room to access the disc nuts. See Item 8 of **Figure 6**.* The adhesive on the plastic disc will need to be carefully removed with a razor blade or some other sort of scraping tool. Set the plastic disc aside for later use.
3. Your assembly should now look like what is shown in **Figure 7**.

ITEM NO.	PART NUMBER	DESCRIPTION	QTY.
1	545-6835-00	SPINNING DISK, PLASTIC, TRON	1
2	530-6572-00	HUB, SPINNING DISK, TRON	1
3	545-6836-00	ADHESIVE PAD - SPINNING DISK	1
4	545-6836-01	ADHESIVE PAD - SPINNING DISK	1
5	237-6023-01	SCREW, 8-32 X 5/8 PFH MS	3
6	240-5102-00	8-32 NYLON LOCK NUT	3

ASSEMBLY, SPINNING DISK/HUB, TRON
511-6925-00

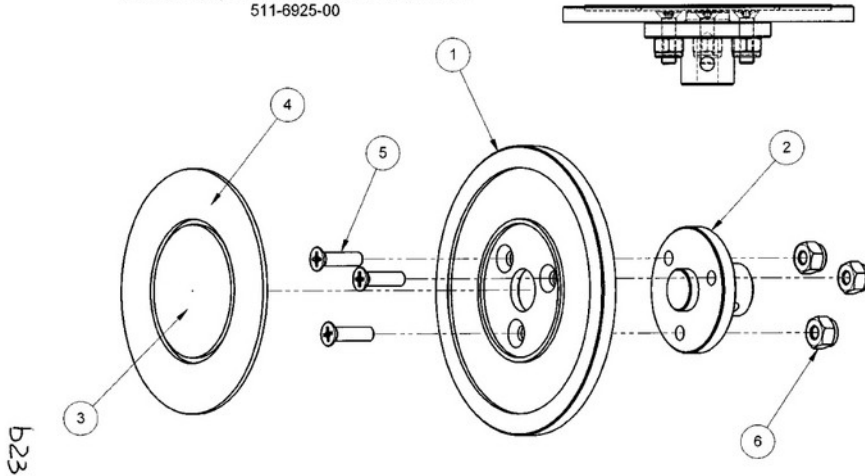

Figure 5

b24

ITEM #	PART NUMBER	DESCRIPTION	QTY.
1	535-0453-00	MOUNTING BRACKET, SPINNING DISK, TRON	1
2	515-7769-00	MOTOR BRACKET, SPINNING DISK	1
3	511-5190-00	MOTOR ASSEMBLY, TRON DISK	1
4	237-6014-00	M5 X 0.8 X 8 PH SELF LOCKING SCREW	4
5	242-5028-00	WASHER NYLON .285 X .688 X .063	1
6	511-6925-00	ASSEMBLY, SPINNING DISK/HUB, TRON	1
7	237-6092-00	SET SCREW, 10-32 X 5/16, SOCKET CUP PT	1
8	237-5995-00	#10-32 x 1/2 HWH NO SLOT SERR ZI	2
9	242-6003-00	#10 FLAT WASHER - 1/2" O.D. X .062 THICK	2

ASSEMBLY, SPINNING DISK, TRON
500-7201-00

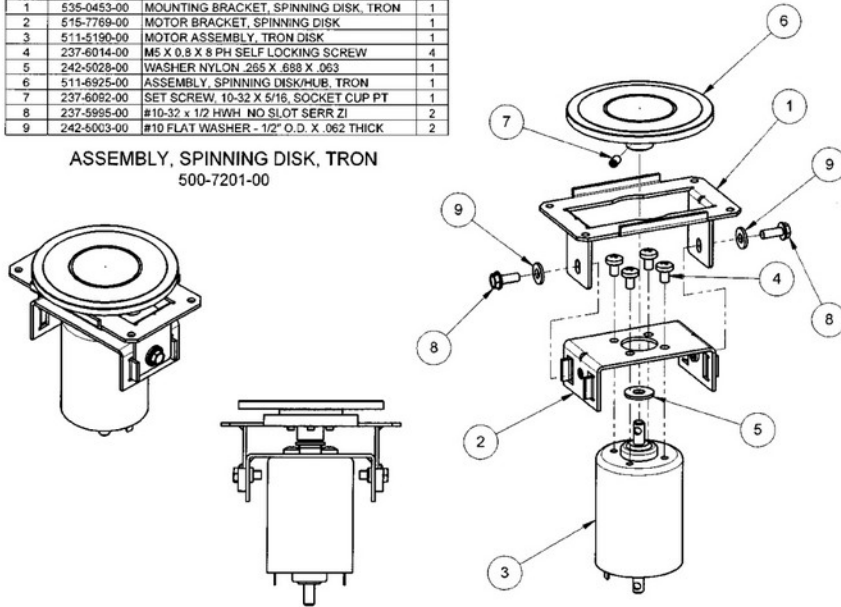

Figure 6

Step 7: Installing the LED ring assembly and associated mounting brackets and hardware.

1. Completely remove the two side assembly height adjustment screws using a 5/16" wrench to allow separation of the top portion of the spinning motor assembly. See Items 8 and 1 in **Figure 6**.
2. With the top bracket now removed and on a work surface, begin to mount the LED ring assembly in place with the included hardware along with lower mounting bracket. Start by placing the top LED ring bracket assembly as shown in **Figure 8**. Using the supplied #4 tapered screws in the top inner four holes of the LED bracket assembly, guide the lower mounting bracket in place from the bottom as shown in **Figure 9**. Add the flat washers towards the lower bracket followed by the split lock washer and the 1/4" nuts. Loosely tighten all nuts so the LED ring bracket can be centered properly with the main outside corner mounting holes as shown in **Figure 8**. Once centered, do a final tightening of all four nuts. Your top bracket should now look like **Figures 8 and 9**.

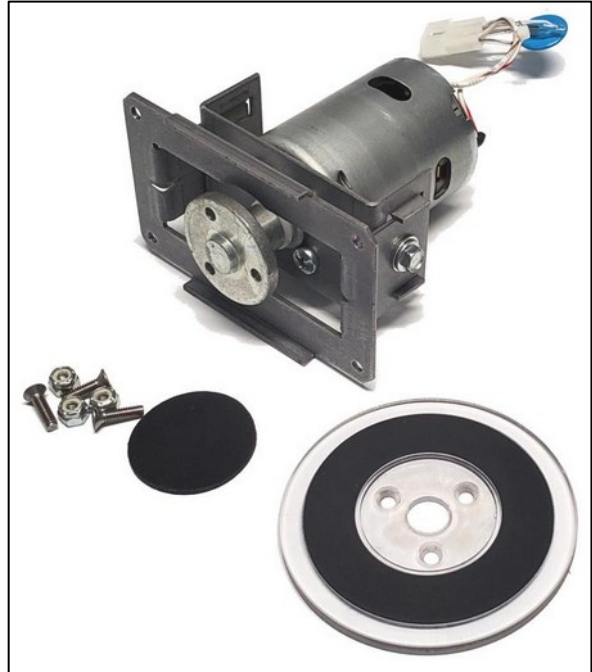

Figure 7

3. Reattach the top bracket back to the lower spinning motor assembly with the original two 5/16" hex head screws and washers. Loosely tighten it just enough so that it can continue to move up and down with some resistance. The screws will be tightened fully later after reinstalling the assembly back in the playfield.

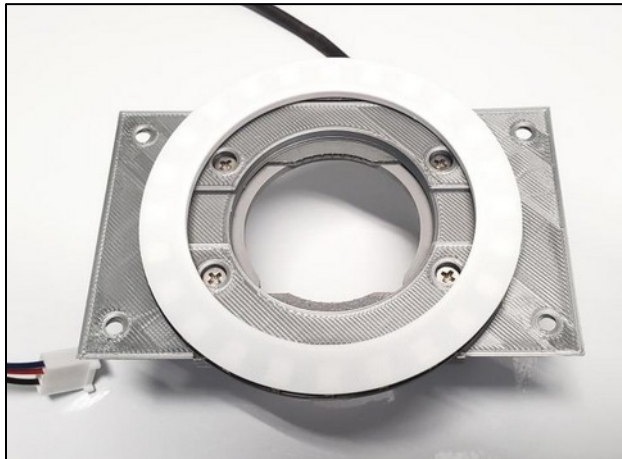

Figure 8

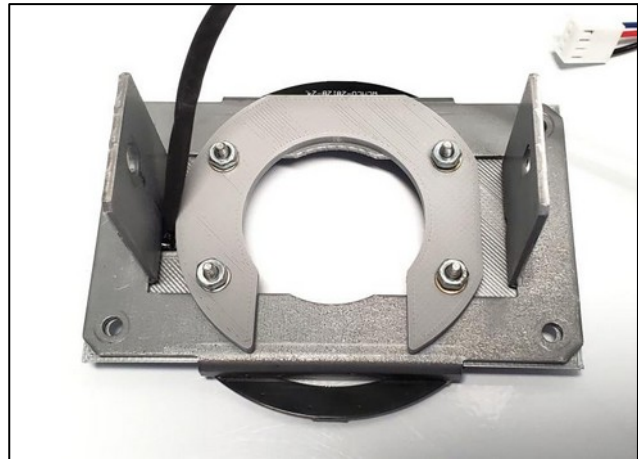

Figure 9

Step 8: Mount the top disc as follows.

1. Install the original plastic disc by placing the included disc shim on top of the spinning disc hub as shown in **Figure 10** followed by the plastic disc. This shim enables better height adjustment later. *Note: Be sure to line up the shim and disc with the mounting holes of the disc hub.*
2. Reinstall the disc mounting screws and nuts that were removed in Step 6.2. *Note: Using angled pliers to hold the nuts while using a Phillips screwdriver to get them started first will make this step much easier.* Take your time since this step can be frustrating.
3. Make sure all three nuts are fully tightened at this point.
4. Your assembly should now look like what is shown in **Figure 11**.
5. Add the supplied adhesive tape to the cleaned bottom side of the top center rubber disc pad as shown in **Figure 12**. Reattach the pad to the plastic disc.
6. The assembly modifications are now complete and should now look like what is shown in **Figure 13**.



Figure 10



Figure 11



Figure 12



Figure 13



Step 9: Reinstall the completed assembly back into the playfield as follows.

1. Holding the assembly with the LED ring harness wires exiting the right side of the assembly, mount it back in position using the original four 1/4" hex head screws from Step 6. *Note: Be mindful of keeping the disc fully centered to the playfield hole as you tighten it down.*
2. Make final disc height adjustment as level as possible to the playfield surface by moving the top bracket up and down as necessary then fully tightening the two height adjustment screws using a 5/16" wrench. See Item 8 of **Figure 6**.
3. Reattach the single two-pin Molex connector to the spinning disc motor assembly.
4. Connect the LED ring harness to the keyed J1 "LED RING" connector of the Controller PCB.

Installation is now complete. If you chose to screw the four empty lamp socket back on the playfield, do so now before testing.

Step 10: Test the functionality of the Spinning Disc LED Effect Mod as follows. If any of these tests fail, reference the Troubleshooting section for help.

1. Power on the TRON machine and verify the LED ring orange "Dual Scan" idle effect is started.
2. Open the coin door and pull out the door safety switch to enable playfield power. Enter service mode and select DIAG > GAME > DISC. Verify "CLOCKWISE" direction by holding down select and verify the LED ring is blue and spinning in a clockwise direction. Let go of SELECT to stop test.
3. Select "COUNTER-CLOCKWISE." Verify "COUNTER-CLOCKWISE" direction by holding down select and verify the LED ring is red and spinning in a counterclockwise direction. Let go of SELECT to stop test.
4. Verify all LED ring effects stop when general illumination (GI) is off. This step cannot be tested from the service menu. You have two options to test this feature. Either play a game and verify the LED ring effect is off when a GI off effect is happening during game play or manually pull the J2 "GI IN" connector on the Controller PCB and verify the LED ring is off.

Testing is now complete, and you are ready to close up the machine and enjoy your Lundy Electronics TRON Spinning Disc LED Effect Mod.

Troubleshooting

Issue: Initial power-up of machine and the LED ring does not display the orange "Dual Scan" effect.

- Verify power to the Controller PCB by verifying the red LED is illuminated on the NANO board attached to the Controller PCB. If LED is illuminated, the Controller PCB is getting power and proceed to the next step. If not, verify power harness connections from power source to the J3 "POWER IN" connector. If still not getting the red LED on the NANO, you will need to use a volt meter to verify power to the Controller PCB.
- Verify your yellow J2 "GI IN" connection on the Controller PCB and verify alligator clips are making good contact with the tabs of the GI lamp socket.



Issue: There are no LED ring blue or red clockwise or counterclockwise effects.

- Verify your J3 "POWER IN" connection at the Controller PCB is seated correctly as well as the six-pin motor relay direction tap.
- Verify your J1 "LED RING" connection is seated correctly.
- Inspect both ends of J1 and J3 wiring harnesses for damaged or loose pins pulled out of the sockets.

If you still have issues, contact Lundy Electronics at <https://lundyelectronics.com/contact-us>.

Thank you for choosing Lundy Electronics, and we hope you enjoy your pinball product.



Rev B. All specifications and included hardware are subject to change.

<http://www.lundyelectronics.com>